



Qualität von Anfang an.

Technische Daten

BAUFORM

3-teilige Körperkonstruktion (verschraubt), wartungsfrei, mit vollem Durchgang. Flanschplatte nach ISO 5211 für Antriebsaufbau. Stempelung nach AD-Merkblatt A4, **Fire-Safe Zulassung, Anti-Static Ausführung und TA-Luft Zulassung.**

BESONDERHEITEN

- Flanschplatte für Antriebsaufbau mit Doppellochkreis
- Handhebel in AUF- und ZU-Stellung abschließbar
- Spindelpackung mit Tellerfederpaket und Sicherungsblech, wartungsfrei
- Gehäuseteile mit Zentrier-Nut und Feder, zum leichten und zentriergenauen Zusammenbau (z.B. nach dem Verschweißen)

BETÄTIGUNG

90°-Drehung des Handhebels.
Um jeweils 90° gegen die Spindel versetzbar.

ANSCHLUß

Innengewinde ½" bis 4", DIN 2999
Anschweißenden DN15 - DN100.

BAULÄNGE

Gewinde DIN 3202 M3
Anschweißenden DIN 3202 S13

BETRIEBSDRUCK

Großvakuum bis Nenndruck (bis +80°C).

TEMPERATUR

-30°C bis max. +180°C

Bei Mediumtemperaturen über 80°C, bzw. stark schwankenden Mediumtemperaturen, empfehlen wir eine Druckausgleichsbohrung in der Kugel. Bei zur Dampfbildung neigenden Medien ist eine Ausgleichsbohrung zwingend erforderlich.

Bitte bei Ihrer Bestellung angeben.

WERKSTOFFE

Gehäuse: Edelstahl 1.4408
Kugel: Edelstahl 1.4408
Kugeldichtung: PTFE-glasfaserverstärkt
Spindeldichtung: PTFE / FKM
Handhebel: Edelstahl

ZUSATZAUSSTATTUNG

Pneumatischer oder elektrischer Schwenk-antrieb; elektrische Stellungs-anzeige.

BESONDERHEITEN

Auf Wunsch mit hohlraumarmer Kugeldichtung.

Alle Angaben sind freibleibend und unverbindlich!

Specification

DESIGN

3-piece design (screwed), maintenance free, full bore. Mounting pad for actuator according to ISO 5211.

Stamped to AD-approval A4, **Fire-Safe approval, Anti-static device and TA-Luft approval.**

FEATURES

- Mounting pad for actuator with two scribed circles
- handle lockable in open and close position
- Stem seals with spring washer set and lock plate, maintenance free
- Body parts with centring grooved and tongued, for ease assembly (e.g. after welding)

OPERATION

Rotation of the handle through 90°. (Handle is reversible through 90°)

CONNECTION

Female B.S.P. thread ½" - 4", DIN 2999
Butt welding DN15 - DN100.

FACE TO FACE

Threaded connection DIN 3202 M3
Welded connection DIN 3202 S13

PRESSURE RANGE

Almost vacuum up to nominal pressure (up to 80°C).

TEMPERATURE RANGE

-30°C up to +180°C

At media temperature above 80°C or large oscillating media temperatures we recommend a pressure compensation bore in the ball. At media which tend to steam-building the pressure compensation bore is compellingly required.

Please mention in your order.

MATERIALS

Body: Stainless steel 1.4408
Ball: Stainless steel 1.4408
Ball seals: PTFE-glassfiber-reinforced
Stem seals: PTFE / FKM
Handle: Stainless steel

OPTIONS

Pneumatic or electric actuator, electrical position indicator.

CHARACTERISTICS

Cavity-free type on request.

The above information is intended for guidance only and the company reserves the right to change any data herein without prior notice!

Artikel:

ZA

2-Wege Kugelhahn
Voller Durchgang
PN 64

Edelstahl



Type:

ZA

2-Way Ball Valve
Full bore
PN 64

Stainless Steel



Art. ZA - Seite 1/4

Artikel- u. Bestellangaben: z.B. ZA311025

= 3-teiliger Kugelhahn, Edelstahl / PTFE / Edelstahl, mit Handhebel, 1"

1.+ 2. Stelle Produkt	3.+ 4. Stelle Werkstoffe Gehäuse/ Dichtung/ Kugel	5. Stelle Betätigung	6. Stelle Zusatzausstattung	7.+ 8. Stelle Anschlußgröße (nach DIN 2999)																	
ZA = Kugelhahn, voller Durchgang, 3-teilige Ausführung	31 = Edelstahl / PTFE / Edelstahl	0 = ohne Handhebel 1 = mit Handhebel	0 = ohne 3 = hohlraumarm																		
				<table> <tr> <td>Gewinde</td> <td>Anschweißenden</td> </tr> <tr> <td>23 = 1/2"</td> <td>62 = DN 15</td> </tr> <tr> <td>24 = 3/4"</td> <td>63 = DN 20</td> </tr> <tr> <td>25 = 1"</td> <td>64 = DN 25</td> </tr> <tr> <td>26 = 1 1/4"</td> <td>65 = DN 32</td> </tr> <tr> <td>27 = 1 1/2"</td> <td>66 = DN 40</td> </tr> <tr> <td>28 = 2"</td> <td>67 = DN 50</td> </tr> <tr> <td>29 = 2 1/2"</td> <td>68 = DN 65</td> </tr> <tr> <td>30 = 3"</td> <td>69 = DN 80</td> </tr> <tr> <td>31 = 4"</td> <td>70 = DN 100</td> </tr> </table>	Gewinde	Anschweißenden	23 = 1/2"	62 = DN 15	24 = 3/4"	63 = DN 20	25 = 1"	64 = DN 25	26 = 1 1/4"	65 = DN 32	27 = 1 1/2"	66 = DN 40	28 = 2"	67 = DN 50	29 = 2 1/2"	68 = DN 65	30 = 3"
Gewinde	Anschweißenden																				
23 = 1/2"	62 = DN 15																				
24 = 3/4"	63 = DN 20																				
25 = 1"	64 = DN 25																				
26 = 1 1/4"	65 = DN 32																				
27 = 1 1/2"	66 = DN 40																				
28 = 2"	67 = DN 50																				
29 = 2 1/2"	68 = DN 65																				
30 = 3"	69 = DN 80																				
31 = 4"	70 = DN 100																				

Ordering example: e.g. ZA311025

= 3-piece design ball-valve, stainless steel / PTFE / stainless steel, with handle, female B.S.P. thread, 1"

1.+ 2. Digit Product	3.+ 4. Digit Material Body / Seal / Ball	5. Digit Operation	6. Digit Options	7.+ 8. Digit Connection size (acc. to DIN 2999)																	
ZA = Ball-valve, full bore, 3-piece design	31 = Stainless steel / PTFE / Stainless steel	0 = without Handle 1 = with Handle	0 = no option 3 = cavity-free																		
				<table> <tr> <td>threaded connection</td> <td>Butt welding</td> </tr> <tr> <td>23 = 1/2"</td> <td>62 = DN 15</td> </tr> <tr> <td>24 = 3/4"</td> <td>63 = DN 20</td> </tr> <tr> <td>25 = 1"</td> <td>64 = DN 25</td> </tr> <tr> <td>26 = 1 1/4"</td> <td>65 = DN 32</td> </tr> <tr> <td>27 = 1 1/2"</td> <td>66 = DN 40</td> </tr> <tr> <td>28 = 2"</td> <td>67 = DN 50</td> </tr> <tr> <td>29 = 2 1/2"</td> <td>68 = DN 65</td> </tr> <tr> <td>30 = 3"</td> <td>69 = DN 80</td> </tr> <tr> <td>31 = 4"</td> <td>70 = DN 100</td> </tr> </table>	threaded connection	Butt welding	23 = 1/2"	62 = DN 15	24 = 3/4"	63 = DN 20	25 = 1"	64 = DN 25	26 = 1 1/4"	65 = DN 32	27 = 1 1/2"	66 = DN 40	28 = 2"	67 = DN 50	29 = 2 1/2"	68 = DN 65	30 = 3"
threaded connection	Butt welding																				
23 = 1/2"	62 = DN 15																				
24 = 3/4"	63 = DN 20																				
25 = 1"	64 = DN 25																				
26 = 1 1/4"	65 = DN 32																				
27 = 1 1/2"	66 = DN 40																				
28 = 2"	67 = DN 50																				
29 = 2 1/2"	68 = DN 65																				
30 = 3"	69 = DN 80																				
31 = 4"	70 = DN 100																				

Druck-Temperatur-Diagramm / Pressure-Temperature-Diagram

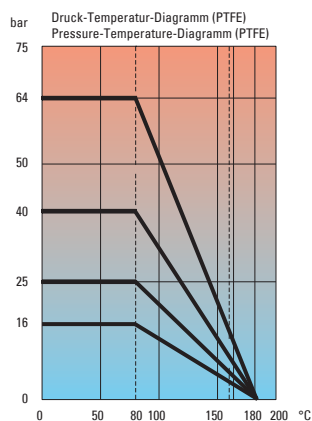

Kv-Wert / Kv-value

Größe / Size ["]	Kv-Wert / Kv-value [m³/h]
1/2	36
3/4	59
1	90
1 1/4	159
1 1/2	230
2	418
2 1/2	725
3	1098
4	1768

Schweißanleitung für Artikel mit Anschweißenden:

Anschlußteile vom Hahnmittelstück entfernen um eine Beschädigung der Dichtungen durch die Schweißtemperatur zu verhindern. Bei bereits fest verlegten Rohren anstelle des Hahnmittelstückes ein Distanzstück zwischen den Anschlußteilen einspannen und mit den

Zugstangen verschrauben. Vor dem Anschweißen darauf achten, daß die Enden der Rohrleitungen gut fluchten. Nach dem Schweißvorgang und erfolgter Abkühlung das Mittelstück montieren.

Welding instructions for parts with welded connections:

Remove connection parts from the middle-part of the valve, to prevent damage of the seals due to high welding-temperatures. In case of already installed pipework, insert a distance-part between the

connection parts and fix it with the help of the tie-rods. Before welding ensure that the pipe-connections are aligned. After successful welding and cooling reassemble the valve.



Stückliste / Parts list

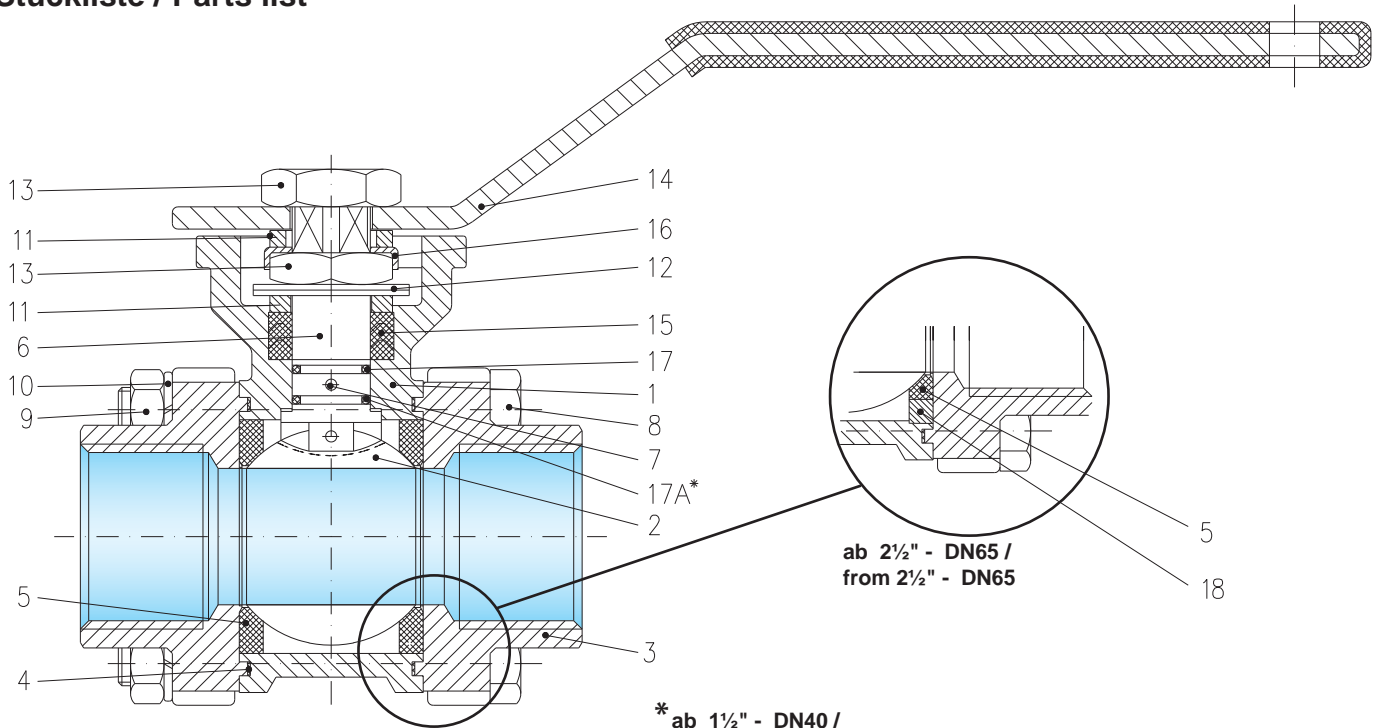

ab 2 1/2" - DN65 /
from 2 1/2" - DN65

* ab 1 1/2" - DN40 /
from 1 1/2" - DN40

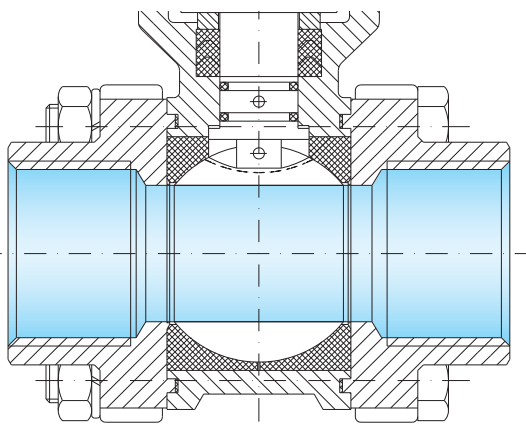

Kugeldichtung bei hohlraumarmer
Ausführung des Kugelhahns

seats at cavity-free version of the
ball valve

Pos.	Bezeichnung / Description	Material / Material
1	Gehäuse Body	Edelstahl 1.4408 Stainless steel 1.4408 (AISI 316)
2	Kugel Ball	Edelstahl 1.4408 Stainless steel 1.4408 (AISI 316)
3	Anschlußende Connection end	Edelstahl 1.4408 Stainless steel 1.4408 (AISI 316)
4	Gehäusedichtung Body seals	Graphit Graphite
5	Kugeldichtung Ball seals	PTFE + 15% Glasfaser verstärkt PTFE + 15% glassfiber reinforced
6	Spindel Stem	Edelstahl 1.4401 Stainless steel 1.4401 (AISI 316)
7	Anti-Static-Ausführung Anti-static device	Edelstahl 1.4401 Stainless steel 1.4401 (AISI 316)
8	Sechskantschraube Hexagon screw	Edelstahl 1.4403 Stainless steel 1.4403 (AISI 304)
9	Sechskantmutter Hexagon nut	Edelstahl 1.4403 Stainless steel 1.4403 (AISI 304)
10	Sicherungsring Lock washer	Edelstahl 1.4403 Stainless steel 1.4403 (AISI 304)
11	Druckring Gland ring	Edelstahl 1.4403 Stainless steel 1.4403 (AISI 304)
12	Tellerfeder Spring washer	Edelstahl 1.4310 Stainless steel 1.4310 (AISI 301)
13	Sechskantmutter Hexagon nut	Edelstahl 1.4301 Stainless steel 1.4301 (AISI 304)
14	Handhebel Handle	Edelstahl 1.4301 Stainless steel 1.4301 (AISI 304)
15	Spindeldichtung Stem seals	PTFE PTFE
16	Sicherungsblech Lock plate	Edelstahl 1.4301 Stainless steel 1.4301 (AISI 304)
17	O-Ring O-ring	FKM FKM
17A	O-Ring (ab 1 1/2" / DN40) O-ring (from 1 1/2" / DN40)	FKM FKM
18	Zentrierring Center ring	Edelstahl 1.4301 Stainless steel 1.4301 (AISI 304)

Dok.-Nr.: KAT-ZA-3/4 26.06.06 - Änderung: Temperaturhinweis eingefügt



Abmessungen / Dimension

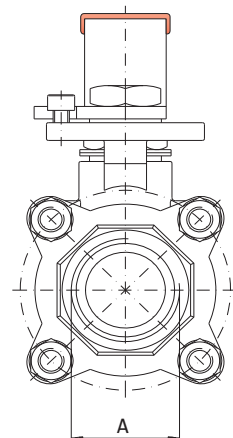
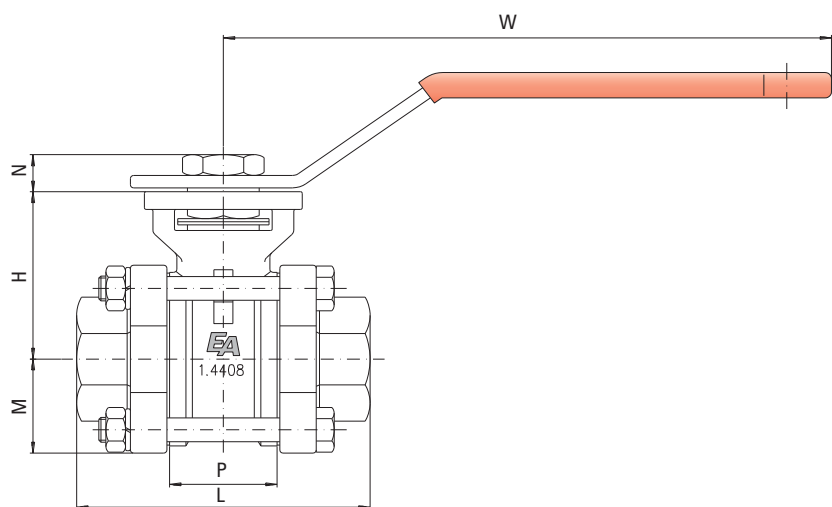
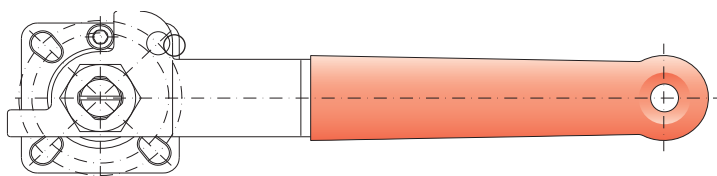

Gewindeanschluß /
Threaded connection

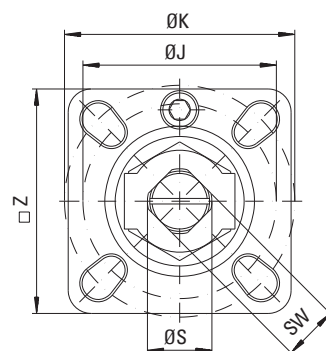
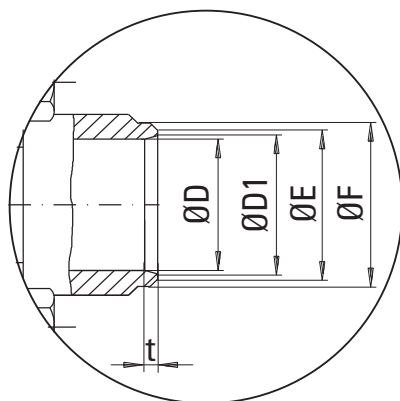
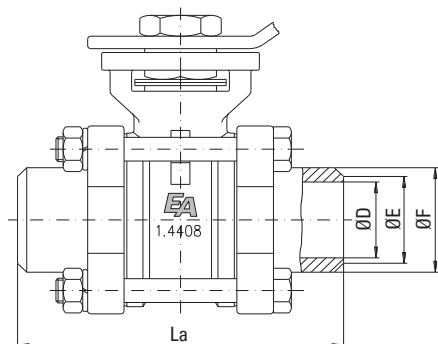

Anschweißenden /
Welded connection

DN15- DN50

DN65- DN100

A	DN	ØD	L	La	ØE	ØF	P	M	H	N	ØK	ØJ	ØS	SW	□ Z	W	kg
1/2	15	16	75	75	17	22,4	25,2	22,5	42,3	8	42	36	11,1	9	42	113,5	0,52
3/4	20	20	80	90	22	28,2	27,9	27,2	44,8	8	42	36	11,1	9	42	113,5	0,81
1	25	24,5	90	100	28	33,7	33	30,3	54	10	50	42	14,3	11	48	186,5	1,26
1 1/4	32	34	110	110	37	44,0	41,2	36,9	59,2	10	50	42	14,3	11	48	186,5	1,86
1 1/2	40	38	120	125	43	50,8	49,3	40,6	73,5	14,8	70	50	18	14	68	221,5	2,95
2	50	51	140	150	54	62,6	63,6	50,1	82,9	14,8	70	50	18	14	68	221,5	4,47
2 1/2	65	65	185	190	70	76,1	82,1	82	107	17,1	102	70	22	17	94	350	9,72
3	80	80	205	220	82	88,9	95,8	88	117,3	17,1	102	70	22	17	94	350	14,91
4	100	100	240	270	106	114,3	117,8	115	132,3	17,1	102	70	22	17	94	350	24,2

EU-Herstellererklärung / EU-Declaration by the manufacturer

im Sinne der EU-Maschinenrichtlinie 98/37/EG (früher 89/392/EWG, Anhang II B)
Hiermit erklären wir, dass die Kugelhähne unter Anwendung nachfolgender harmonisierter Normen entwickelt und konstruiert wurden:

EN ISO 12100:2004	Sicherheit von Maschinen
EN 983: 1996	Fluidtechnische Anlagen - Pneumatik
EN 60204-1: 1992	Elektrische Ausrüstung von Maschinen

we herewith declare that the ball valves have been developed and designed by applying the following harmonised standards:

EN ISO 12100:2004	Safety of machinery
EN 983: 1996	Safety requirements for fluid power systems and components - Pneumatics
EN 60204-1: 1992	Electrical equipment of machinery

Hinweis
Die Kugelhähne sind zum Einbau in eine Maschine bestimmt. Deren Inbetriebnahme ist solange untersagt, bis festgestellt wurde, dass die Gesamtmaschine der EU-Richtlinie entspricht.
as defined by Machinery Directive 98/37/EC (former 89/392/EWG, Annex II B),

Advice
These ball valves are intended to be incorporated into machinery compounds. Putting into operation of the machinery is not allowed until such time as the entire machinery is proving to comply completely with the EU Directive.